

DX-64 Digital Audio and Radio Management System

Radio Dispatch Switch for Mission Critical Networks



omnitronics

INNOVATIVE ELECTRONIC SOLUTIONS



DX-64 DIGITAL AUDIO

The DX-64 adds to our product line a flexible and expandable platform that will complement the 950 and 990 series of Radio Management Systems. With a fully digital backbone and computer driven user interface, this product offers the features required in demanding installations. The design of the DX-64 is the culmination of many years of experience in providing radio management systems to government departments, emergency services and mining companies. Hundreds of 950 and 990 installations are in daily use. Our sales representatives and engineers have listened to communications consultants, operators and system integrators before embarking on this world class product.



Reliability was also a prime consideration in the design of the DX-64. Minimal interconnection between system components, main/standby redundancy for the System Control Unit and hot swapping of interface cards ensures maximum reliability and continuous operation during maintenance.

Perhaps the most appealing factor of the DX-64 is its price. Considering the available features, expansion capacity and quality, the DX-64 offers outstanding value for money.

The full potential and benefits of the DX-64 are difficult to convey in a brochure such as this, so we encourage you contact our sales team for more technical details, and the opportunity to discuss your specific requirements further.

Modular design ensures that the capacity of the DX-64 is totally flexible and allows the system to grow with the user. The system is capable of handling up to 32 operator positions each of which can control, monitor, group and link a maximum of 56 radio, audio or telephone channels. With systems starting with 2 operators controlling 8 radio channels, integrators are able to offer cost-effective solutions knowing that future expansion is ensured. Expansion beyond the local site is also possible using our E1 card and connection to "wide area networks".





MANAGEMENT SYSTEM

DX-64 SYSTEM DIAGRAM FOR 16 CHANNELS AND TWO OPERATORS POSITIONS

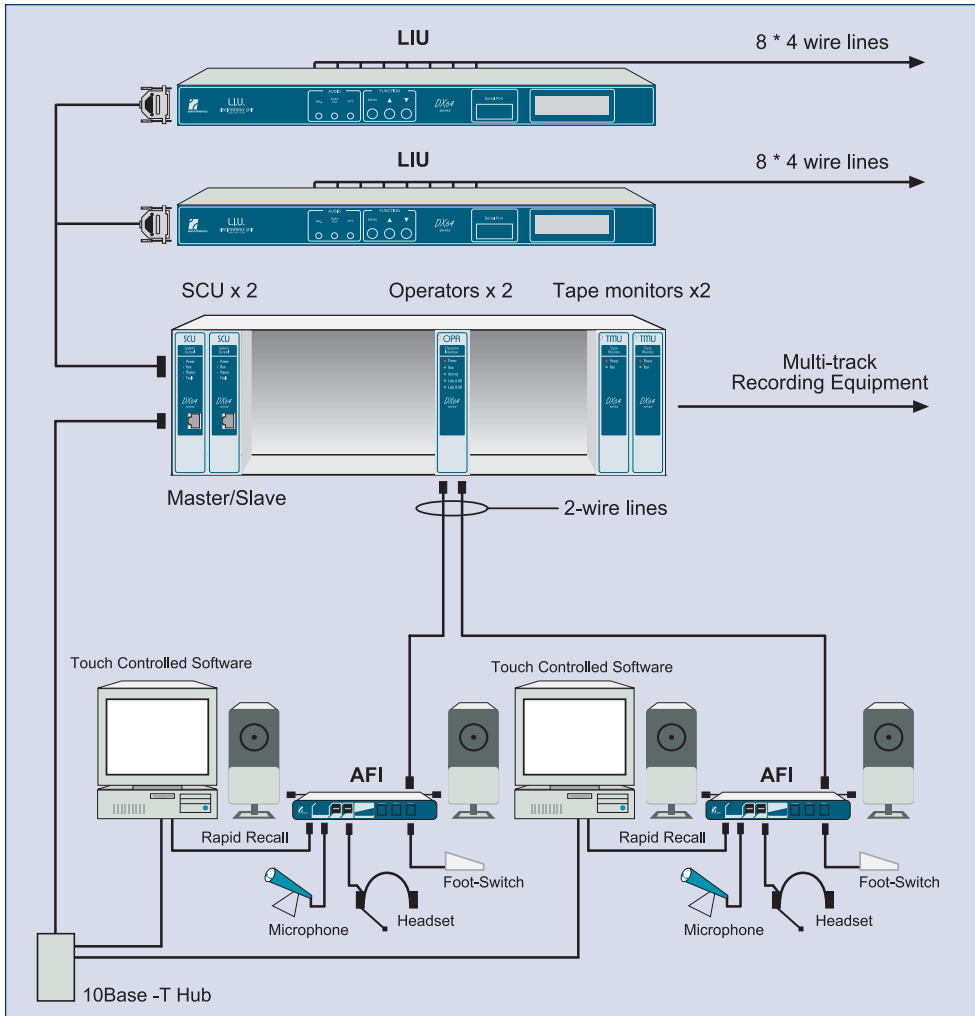

Modular design ensures that the capacity of the DX-64 is totally flexible and allows the system to grow with the user.

► **HIGH RELIABILITY AND EASY MAINTAINABILITY** Dual processor, independent data and audio paths and “hot swapping” set new standards for “mission critical” installations.

► **SPACE SAVING INSTALLATIONS** Use of the latest in surface mount electronics has ensured the smallest possible sub-rack packaging. A flat touch screen and compact audio interface take up a minimum of desktop real estate.

► **FUTURE PROOF DESIGN** The system architecture allows for expansion of capabilities including wide area networking.

► **AUSTRALIAN DESIGN, BACKUP AND SERVICE** OMNITRONICS has been designing and manufacturing radio management products for over 20 years.

► **VALUE FOR MONEY** Feature for feature, the DX-64 Radio Management System easily presents the best value for money on the market today.

► **CUSTOMISATION** Since the DX-64 is entirely designed and manufactured by OMNITRONICS, most specific client demands can be accommodated by our engineering team.

SCREEN SHOTS FROM THE DX-64

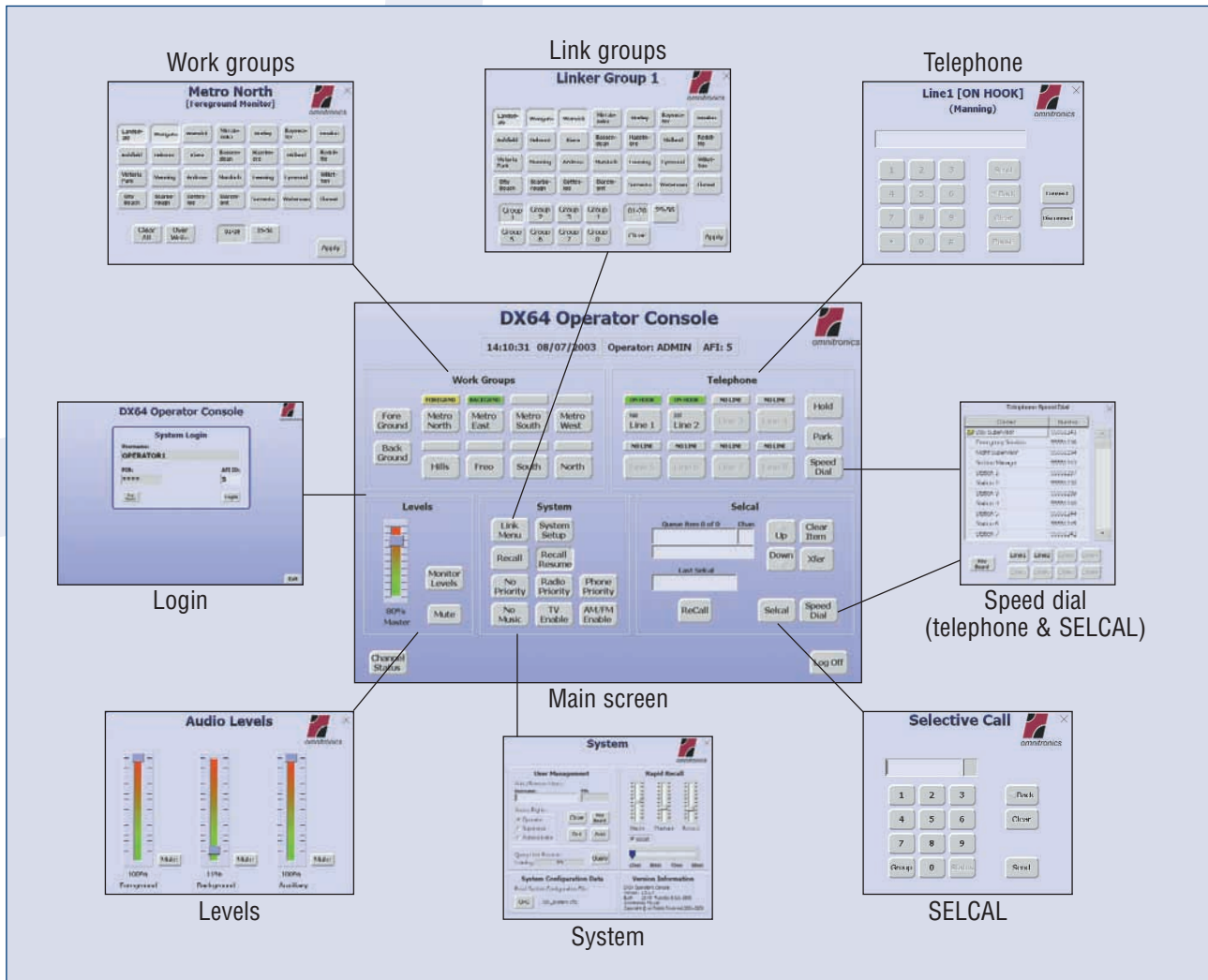

Basic Screen Operations:

- ▶ **LOGIN** Allows up to 32 users to login to the system with three levels of security, each with a 4 digit PIN.
- ▶ **MAIN SCREEN** Normal operational screen for users. All the important activities are controlled and monitored from this position. The “Channel Status” key presents a pop-up “Live Channel” activity display.
- ▶ **AUDIO LEVELS** Level sliders for foreground, background and auxiliary audio levels plus individual mutes.
- ▶ **SYSTEM** Administration login privileges only. Allows the system administrator to configure user positions and control the rapid recall parameters.
- ▶ **TELEPHONE** Manual telephone dialling. (Speed dialling is available on “Main Screen”.)
- ▶ **WORK GROUP** Used to assign available channels to workgroups. Eight groups are configurable, with two groups available for assignment as foreground or background channels.
- ▶ **LINK GROUP** Selection of channels for linked groups. Up to eight groups can be defined using any of the available channels.
- ▶ **SPEED DIAL FOR TELEPHONES AND SELCAL** Searchable address book using minimal keystrokes. Separate screens for SELCAL and telephone.

(Data entries for ‘Login’, ‘System’ and ‘Speed Dial’ screens can be made using a ‘pop-up’ menu via the touch screen instead of a keyboard or mouse.)



SYSTEM CARDS & COMPONENTS

DX-64 SCU - System Control Unit

The heart of the DX-64 is the SCU card. It collects configuration parameters from the operators and initiates all the system control and switching functions. The SCU, due to its critical role in the system, operates as a main/standby pair. The hot standby SCU automatically assumes system and network control if a failure of the main SCU is detected. The operator is alerted about the changeover but otherwise the change is transparent.

Four digital busses are connected to each SCU providing a total of 56 bi-directional audio channels to the line and 56 bi-directional audio channels to the DX-64 OPR Operator Interface cards. The digital busses are capable of handling 64 channels however 8 of these channels are dedicated to high-speed audio switching information.

The SCU collects channel control and configuration information from the operators via a 10Base-T LAN using encrypted TCP/IP packets. This control information is then distributed throughout the components of the DX-64 by a high-speed RS485 bus. This bus is also used to collect diagnostic information that is made available to operators via the LAN.

DX-64 OPR - Operator Interface Card

This card services two operator positions. Connection to the operator position from the OPR is via a two wire, twisted pair, digital interface. This interface is similar to, but not compatible with, a standard ISDN interface and provides two bi-directional digital audio channels per operator. The OPR collects information from the SCU to determine which of the 56 channels to present to the operator as foreground and background audio. The selected receive audio channels are mixed by a DSP, combined with associated control information and streamed to the operator. A maximum of 16 OPR cards can be installed in a system providing 32 operator positions.

DX-64 TMU - Tape Monitor Interface

Any of the 56 channels can be selected for monitoring. The TMU card has an output capacity of eight channels, each of which is a 600ohm, transformer coupled, analog output. The TMU also presents a control output for each group of channels whenever a PTT or Mute is detected on that configured channel. Up to seven TMU cards can be installed so that a fully loaded 56-channel system can be monitored.

DX-64 E1 - Network Interface Card (due for release fourth quarter 2003)

The E1 interface card is a true, industry standard, E1 protocol interface allowing networking of DX-64 systems and access to audio channels from network communication paths. The E1 port will have bi-directional capacity of 28 channels, each of which is presented as a remote channel to the operator.

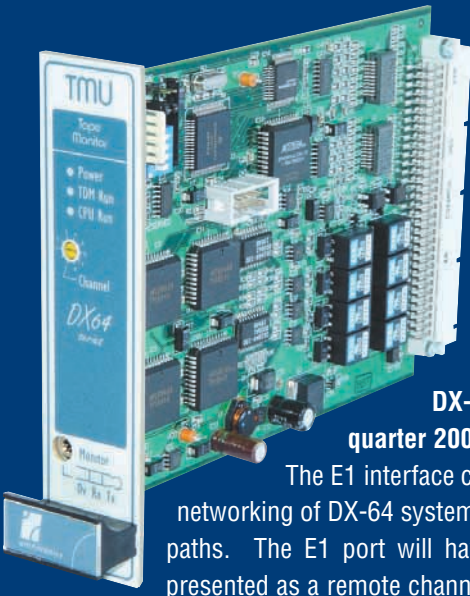



SYSTEM COMPONENTS

DX-64 AFI - Audio Facilities Interface

The AFI is the operators' analog interface to the digital system. Various audio devices such as headsets, desk & gooseneck microphones or handsets are managed by the AFI. Transmit audio is digitised and forwarded to the OPR for connection to the channels selected by the operator. A number of PTT functions are catered for.

Received audio can be arranged into either foreground or background mode allowing the operator to differentiate several sources. Local PABX or PSTN telephone handsets can also be managed by the AFI to provide a convenient single source for all audio control. The AFI also provides an interface to the system's inbuilt Rapid Recall logger.

The AFI can be re-packaged to meet specific requirements.



DX-64 PC/TS - Operator Touch Screen Control

Using a standard IBM compatible PC with a Touch Screen, the operator is able to gain access to all audio channels connected to the system. A friendly Graphical User Interface GUI, has been developed to give the operator full control of audio selection, grouping, selcal and many other system functions. The PC communicates to the SCU via a standard TCP/IP LAN. *It should be noted that if the LAN or the PC fails, operation via the AFI would continue uninterrupted.* Omnitronics recognise many clients will request customisation of the GUI and this requirement can be met.

A separate Configuration and Maintenance utility is available for System Administrators. This utility allows the administrator to configure operating parameters for the LAN and the DX-64 hardware.



DX-64 LIU - Line Interface Unit

The LIU provides an eight-way radio or audio 4 Wire plus E & M interface to the DX-64. Each channel incorporates DTMF and SELCAL or CTCSS or In-band signalling which are fully controllable at the operator positions. All level controls within the LIU can be setup locally by front panel control or remotely by the System Administrator. Level control is performed with digital 'soft' pots. Entertainment channels can also be interfaced into the LIU.

Multiple LIU's can be paralleled onto the digital bus to fully utilise the 56-channel capacity of the DX-64.



DX-64 RF - Rack Frame

The rack frame housing the SCU, TMI, OPR and E1 cards, is a 3RU, 19" standard configuration rack assembly. The 3RU housing with associated 1RU LIU's ensure the system is very economical on rack space.





RATIONALISATION AND REDUNDANCY OVER WIDE AREA NETWORKS

Rationalisation and redundancy is a major concern for network managers and operators. Emergency services and government utilities require the dynamic allocation of Communication Centres in the event of hoax calls, regional threats, or manpower considerations. Everyday requirements like night switching between centres also require more flexibility than is available from an autonomous communications centre.

By integrating an industry standard E1 card the designers have enabled the system to access remote radio channels as though they were locally connected to the DX-64. Redundancy of signal path and wide distribution of radio channels can be achieved by exploiting networks offered by the major bandwidth suppliers. It is likely that many clients will have different networking requirements and Omnitronics will be pleased to assist in network design.

In practice, the network is configured using an administrator application, running on a PC connected to the DX-64 LAN.

There are two distinct functions required to create a Wide Area Network, in which radio channels at one node (DX64 system) are made accessible at other nodes and vice-versa. This is the process of *sharing and assuming* channels.

Sharing Channels

To make radio channels that are connected to local LIU's accessible to operators at other nodes requires that the local channels be *shared with the network*.

Assuming Channels

To access remote radio channels that are connected to LIU's at other nodes requires *assuming those remote channels from the network*.

The Administration application ensures that the active capacity of 56 channels is not exceeded. For example, a DX-64 with 16 local channels is able to utilise its remaining 40 system channels with remote channels from other DX-64 installations.

Redundancy

Redundancy is an important application of sharing and assuming channels. If it were necessary for a regional Communication Centre to unman for any reason, the operation of all of its channels could be assumed by any remote DX-64 installation

DX-64 CONNECTION TO WIDE AREA NETWORKS

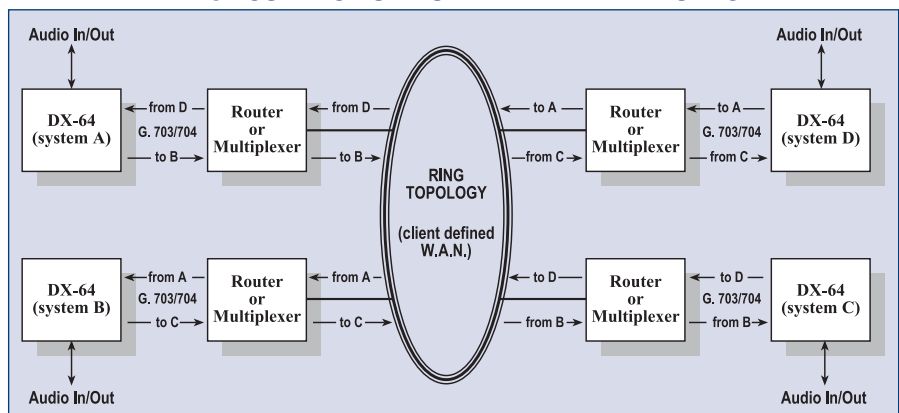

Example of a DX-64 working over a WAN

Using the above diagram as an example, DX-64 installation "A" may be a 16-channel switch. At night, 8 channels are routed from a remote DX-64, installation "B", via its DX-64 E1 Network Interface to installation "A". Utilising third party routers with voice compression to minimise bandwidth usage, all channels are available at the DX-64 "A" for full independent control and monitoring.

A further 16 channels may be distributed from DX-64, installation "C" to installation "A". Utilising the same routers and voice compression, these channels are also available for full independent control and monitoring. A third remote installation "D" may send via landline, a single channel for night time control and monitoring.

Each of these channels would be available to DX-64 installation "A" operators until such a time as the control and monitoring was resumed by their local daytime operators.

Thus a WAN or state-wide network of DX-64 installations could be configured to operate in a format that would maximise operational efficiency.

...the designers have enabled the system to access remote radio channels as though they were locally connected to the DX-64.



SPECIFICATION SUMMARY

- CHANNELS:** 56-channel capacity. These can be any combination of radio, PABX, entertainment or other four-wire audio with "E" and "M" connectivity. Connection to the DX-64 is via the Line Interface Unit, (LIU), which provides isolated ports for audio and control lines.
- OPERATORS:** Up to 32 operator positions with each user having access to all available channels. Control is via an IBM compatible computer using a graphical interface under a "Windows" operating system. Functions include PTT, monitoring foreground and background channels, grouping, linking and telephone. Connection to the DX-64 is by a standard "10 baseT" cable.
- USER INTERFACE:** Each operator position has the choice of control of the system using a touch-screen, mouse or keyboard. From the "MAIN SCREEN", all other functions can be accessed with minimum of keystrokes. Customisation of the screens is available on request. (Charges may apply.)
- AFI:** The Audio Facilities Interface, (AFI), provides a number of options for receiving and transmitting audio. They include dual headsets, loudspeakers, desk mic, Omnitronics 960 handset, rapid recall, PABX and leased line. Provision is also made for a foot-switch PTT operation. In addition, switches for "all call" intercom and PTT are incorporated on the A.F.I. front panel. An independent cable using dual channel digital transmission connects to the DX-64 rack via the OPR card and allows continued operation in the event of computer failure. For minimal installations, the AFI can be used without a controlling computer. The administrator would then do the configuration of the operator position. The AFI is locally powered by 12Vdc. The dimensions are 220 X 230 X 40 mm.
- LIU:** The Line Interface Unit, (LIU), is a 1U subrack which provides the interface between the various channels, (radio PABX etc), and the DX-64 subrack. Each LIU has eight isolated four wire audio lines, plus associated E and M leads. Electrical connection is identical to the OMNITRONICS 619 audio bridge standard, i.e. audio I/O has 600 ohm transformers operating at 1V p-p, the E lead is opto-isolated and can be configured as voltage driven or contact driven and the M lead is a relay contact and can be configured as voltage free or voltage out. The LIU also provides for SELCAL or CTCSS coding and decoding plus in-band signalling functions. All the standard international signalling standards are catered for. Level setup can be done from the front panel or from the system administrator. A back-lit LCD shows the activity status and receive levels. Up to 7 LIU's can be paralleled together giving a total of 56 available channels. Connection to the DX-64 SCU card is by a high-speed TDM data channel. The LIU operates from a nominal 12Vdc-24Vdc source.
- RACK FRAME:** The subrack housing the DX-64 cards is a 3RU, 19" standard assembly. The cards contained are the System Control Unit, (SCU), and its standby, the Tape Monitor Interface, (TMU), Operator's Interface Card, (OPR), and the E1 Network Interface Card. The cards operate from a nominal 12Vdc-24Vdc supply.
- SYSTEM CONFIGURATION:** The basic DX-64 system will comprise of an LIU which can handle 8 channels, a rack frame holding two SCU's, (main and standby), an OPR, (which provides two operator positions), and an operator station made up of a computer, touch-screen and AFI. Options include a TMU for monitoring calls, E1 card for connection to a wide area network and the various operator interface equipment such as headsets foot switches etc. By way of example, a system with 3 x LIU's, 2 x SCU's, 2 x TMI's, 8 x OPR's and an E1 card would handle 24 channels, have 16 operator positions and provide tape monitoring for all positions plus access to a WAN. This would only take up 6 RU of rack space.

West Coast Office: 15 Hector Street, Osborne Park, WA 6017, Australia
Tel: +61 8 9445 2633 Fax: +61 8 9445 1687

East Coast Office: 301 Coronation Drive, Milton, QLD 4064, Australia
Tel: +61 7 3369 5733 Fax: +61 7 3369 5799